

# j POLES

(C) 1959-2011 G F 'Funk' Rogers <K4ABT

## HANDBOOK, 4TH EDITION

Serving HAM Radio since 1959, On the Web Since 1995  
Order Toll Free Monday through Friday, 9 am to 5 pm, 1 800 726 2919 or 1 866 300 1969, All Times, Eastern

NO MINIMUM ORDERS. Same Day Shipping, except Sunday and Holidays BUXCOMM Corporation 115  
LUENBURG DRIVE EVINGTON, VIRGINIA 24550  
BUXCOMM Tech Support is by expert ARO's, Technicians and Engineers. \*Tech Support; Email; [support@buxcomm.com](mailto:support@buxcomm.com)

### **A touch of Class, The Windom and the J-POLE**

*By Glynn E. "Buck" Rogers Sr (68 years as K4ABT)*

The J-POLE has been around since the early days of HAM Radio, and is a direct descendant of the "Windom" Like the Windom or ZEPP, the J-POLE is a spin-off, or a modified WINDOM for VHF and UHF. One of the first articles I wrote about the J-Pole was in HRC magazine in 1958. Since 1958, I've written several j-pole articles in other HAM Radio publications.

Here, my references are to the early, 1923 (version) Windom (Article by Loren G. Windom September 1929, QST magazine). If you look at the feed of the early Windom that was fed with a single wire, you may soon see the similarity between the Windom, ZEPP, and the J-Pole.

Look close at the configuration of the Jpole and the Windom, and you will understand why in many of my articles in CQ Magazine and other publications, that I often refer to the Jpole as a Windom, with the short section folded back on itself to form the parasitic element. It is for this reason that I feel these are two of the best antennas ever designed. Having said this, you will also note that the Windom (and the Jpole) are powerful antennas that provide outstanding performance on all bands *above* the band for which they are cut or designed for.

The reason these two antennas perform so well (as Multi-Band antennas; Windom for HF & lo VHF, Jpole VHF & UHF), is because they operate at harmonics of the fundamental or lowest frequency for which they are cut/designed. To add additional feeders (ladder-line), other than 50 ohm coax or UNUNs is a waste of RF energy. Only 50 ohm coaxial cable and a BALUN at the feed-point is all that is necessary. Anything more, adds losses into the equation that cannot be overcome after-the-fact.

Remember the axiom:

**"When you have reached perfection, anything more becomes a point of diminishing returns."** *Enough said!*  
Trust me on the above paragraph, as I have experimented with every Windom and Jpole concept or design that can be imagined. Having built and sold thousands of these two antennas, I've found that It's difficult to improve on perfection.

**For now, let's look at some of the features of our J-Pole, whether for; 140-150 MHz, or 430-450 MHz**

- the J-Pole is easy to erect
- the J-Pole needs no radials
- the J-Pole has low angle radiation
- the J-POLE has greater bandwidth.
- the J-Pole has greater immunity to terrestrial noise
- the J-Pole is great for local nets or distant repeaters
- the J-Pole has more gain than most Ground Planes
- the J-Pole is more durable than most Ground Planes
- the J-Pole meets most "stealth" antenna restriction agreements
- the J-Pole has less static-charge noise, and static-charge build-up.

---

In the mid-fifties, and early sixties, ridged copper was difficult to find, and even if we were fortunate enough to locate ridged copper, the cost was prohibitive. Most of our VHF (don't even think about UHF) operating was AM (for the late model HAM, "Amplitude Modulation"), and on two meters, operating was centered around 144 MHz. We either opt'd for a bamboo spreader cubical quad, or folded "zepp," as we called it in those days (now-a-days, called a "J-Pole.")

Another variation to this antenna construction was to use electrical thin-wall conduit or "EMT." EMT actually means "electrical metallic thin-wall" but somehow early acronyms had a way of getting turned around, or inverted, . . . or perverted.. hi.

Using metal EMT instead of copper, we learned to use the brazing rods and torch to fabricate our "folded (zepp) Jay." In any case, we were able to make the J-Pole happen. For VHF, the *J-Pole* became the antenna of choice, just as the *Windom* took its place as the antenna of choice for the lower (HF) bands. As a matter of interest, look close at both the J-pole and the Windom, and you might find a close resemblance and maybe even some relationships in the off-center method used to feed each of them.

I've heard of J-poles stacked, collinearized, and some with weird fitted, 1955 Ford fender-skirts. Depending on who's telling the story, they might have more gain than a yagi on a helicopter at 1200 feet, or they won't reach a hand-held across the backyard. I try to make it a personal point to stay out of these CB University fences. You can put a "mini-skirt" on it, you can even place a "tutu" on the J-Pole, but the truth is, it remains a Jpole.

As a personal observation throughout my 64 years as a HAM; **Mistakes, Experience, and Knowledge** has given this ole HAM the **Wisdom** *to know the difference*. **Don't try to build a Windom for two meters, and for heavens sake, DO NOT attempt building a J-Pole for seventy-five (75) meters.** As they say, "do the math;" Just the long, vertical section of a 75 meter J-pole would near 200 feet.

#### **TO THE POINT OF OUR SUBJECT:**

I've had many requests for a ready-made J-pole design that will enable the Amateur Radio user to print the image from a web page and go directly to the construction table and build a J-Pole antenna for their HAM Radio station.

On this page you will find many illustrations I've drawn to help you understand the manner in which a J Pole is built.

Fabrication can sometimes be a problem for the apartment dweller, or the HAM with limited facilities for this kind of project.

[For these reasons, you may wish to purchase the "direct fed Jpole" ready to install. We offer this BUXCOMM J POL in two versions;](#)

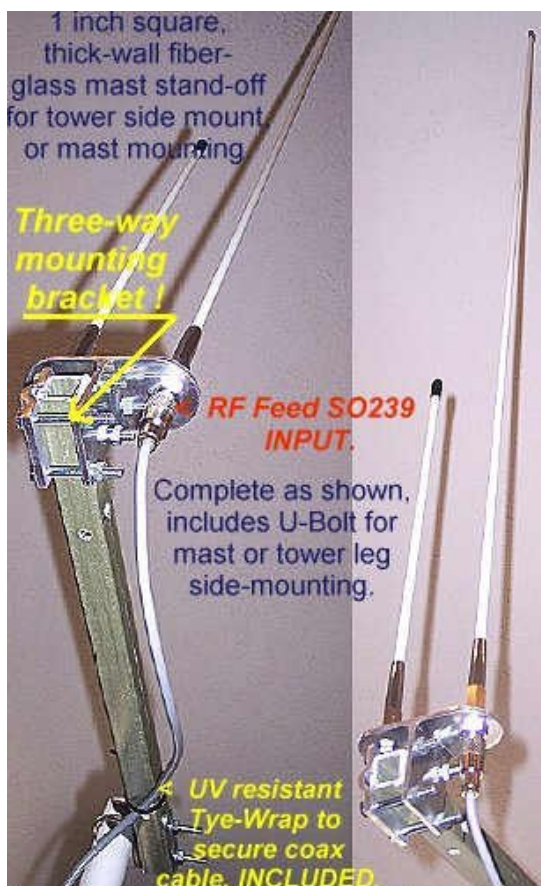

## A VARIATION ON A THEME:

Let's look first at [FIGURE 1a](#). This is the overview and profile of the J-Pole we will be working with. There are two different bands we will be building the J-Pole antennas for. NO, we will not build a two band antenna on one mast. I've been there, done that.. and it is an exercise in futility.

For openers, I would like to show you that all J-poles are not created equal. By that statement; I mean, we will modify our construction techniques a bit and apply a variation to the theme. Notice in the exploded view at [FIGURE 1b](#), I've deviated from the usual RF feed technique that we normally use to attach our coaxial cable to the J-pole.

Where we usually attach the shield and center conductor to the tuning stub and the driven element with aero-seal (hose) clamps, here we've made a slight change in the design by exchanging the elbow for a tee. Below the short (1/4 wave tuning stub) section, we (carefully) soldered an SO-239 (Chassi-mount) coax (female) connector.

But notice that we must first attach a piece of **number 12 or 14** insulated, copper wire to the SO-239. The length of this wire depends on the spacing between the stub and [\(Fig 1A "D"\)](#) long section of our antenna.

If the antenna is for six meters, the wire length will need to be about, 10 to 12 inches long. If our antenna is for two meters, the wire length will be less than 8 inches overall.

I am careful when I (Benz-O-Matic torch) solder the SO-239 to the copper tee, since I don't want to heat the SO-239 to the point the solder on the wire melts and I have to begin the process again.

Shown below & above are our direct feed J-Poles.

**For 2 meters (145.000 to 146.000 MHz) the EXACT dimensions are:**

- A = 58 inches overall (Long, driven element).
- B = 19.5 Inches
- C = 2 Inches
- D = 1.8 Inches (space)

**For 6 meters (50.500 to 51.500 MHz) the EXACT dimensions are:**

- A = 166-3/4 inches overall (long, driven element).
- B = 58-3/4 inches (short, tuning stub).
- C = 5.5 Inches
- D = 5 inches

**USE BUX "VBALUN" with J-Poles 1 kw VHF & UHF BALUN, BUX VBALUN**

**> CLICK HERE for on-line CATALOG**

Hi-Q, toroid design, wound with teflon covered, silver wire.  
For VHF beams, J-Pole matching applications, and construction.

---



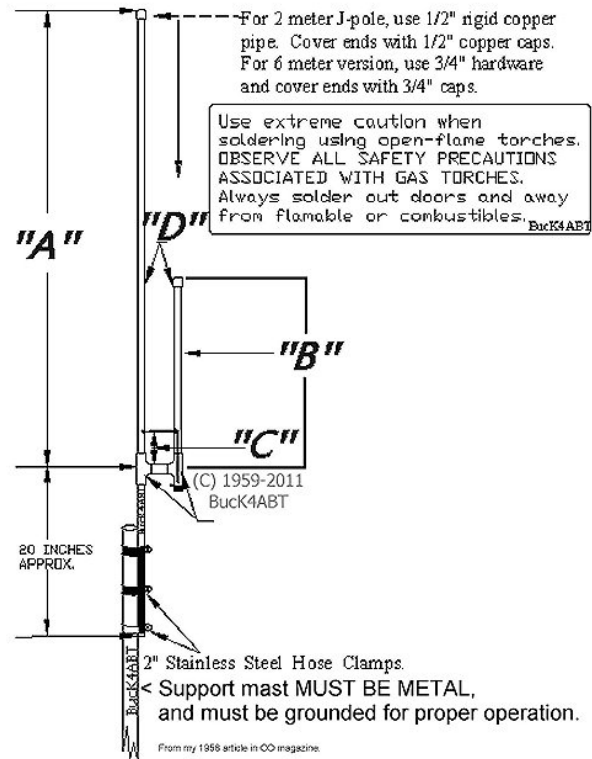

**FIGURE 1a**

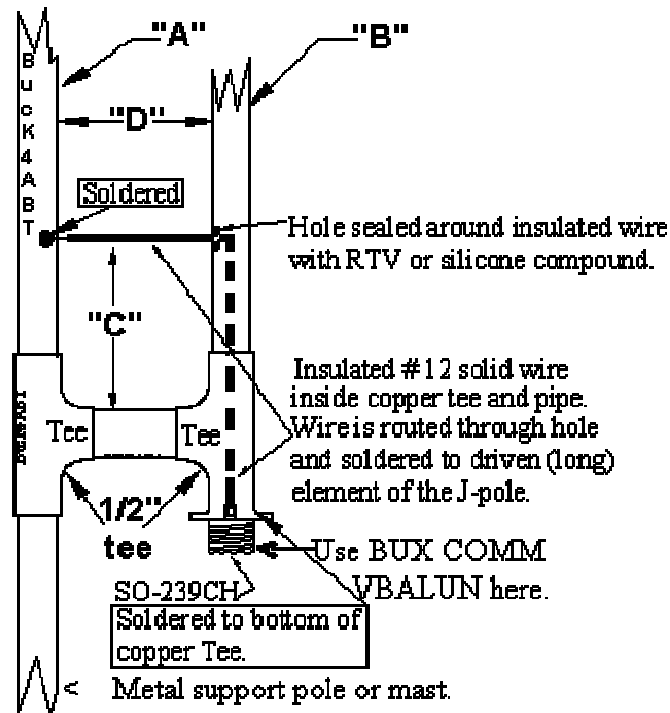

**Exploded view of the RF feedpoint method.** (C) 1959-2011 G E "Buck" Rogers K4ABT

Figure 1b

**NOTE: Coax center conductor attaches to the "Long section" feed point. Shield attaches to the short section feed point.**

**USE BUX "VBALUN" with J-Poles 1 kw VHF Balun, BUX VBALUN**

**> CLICK HERE for on-line CATALOG**

**Hi-Q, toroid design, wound with teflon covered, silver wire.  
For VHF beams and J-Pole matching applications, and construction.**

**An adjustable VSWR, 2 meter J-Pole**

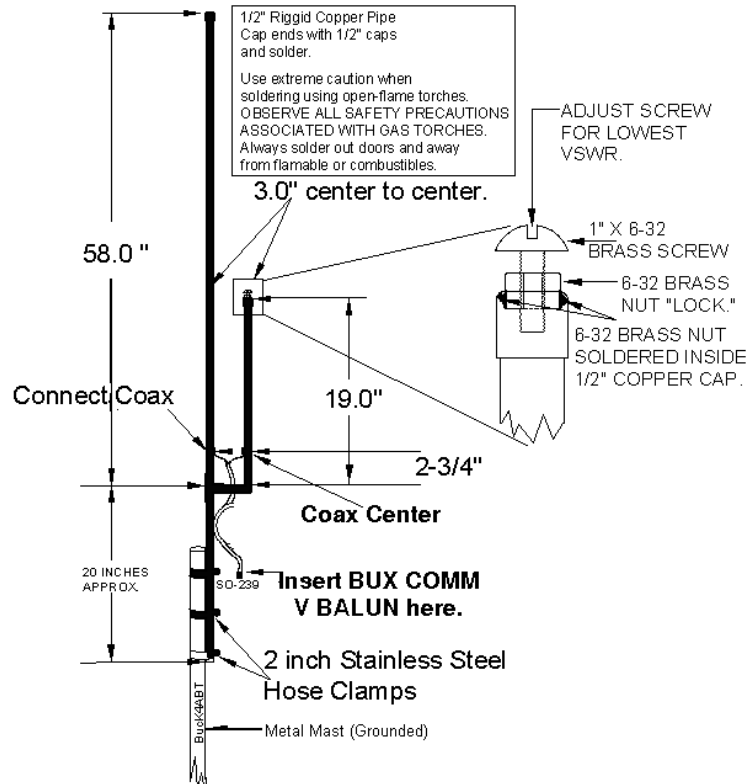

Two Meter J-POLE WITH VSWR ADJUSTMENT.  
(C) 1959-2011 G E "Buck" Rogers K4ABT

BUX VBALUN should be installed at the antenna feed point, or where the coax or feed-line attaches to the J-Pole antenna. BUX BALUNS are used to connect balanced antennas to unbalanced transmission lines, such as coax cable. Their primary purpose is to prevent antenna (RF) currents from flowing down the outside of the cable (VSWR). Another function of the BUX BALUN41 is to match the impedance of an unbalanced coax to the antenna feed point. BUX LISO BALUNS may also be used as "line isolators" anywhere along the cable to prevent the destructive influence of induced RF currents (VSWR). BUX 1:1 BALUNS are current BALUNS. They consist of several large, number 73, ferrite cores.

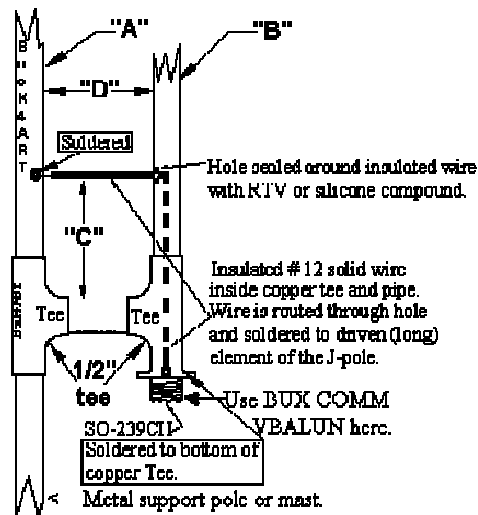

Exploded view of the RF feedpoint method. (C) 1959-2011 Buck4ABT

**CLOSE UP of the alternative coax feed method.  
Use BUX VBALUN to couple coaxial cable to J-Pole.**

My Hardware J-Poles from 1959 & BUXCOMM J2JAY (1995)

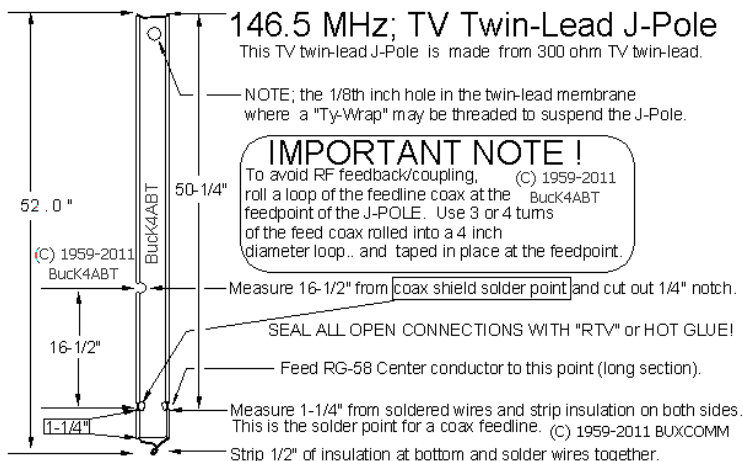

In the early days of packetRadio, we used this Jpole as an Indoor antenna to hit the local Packet Nodes (PacketRepeater). Unbelievable performance when suspended vertically near a window or off the patio. Gain is 3.7 dbi MOL.

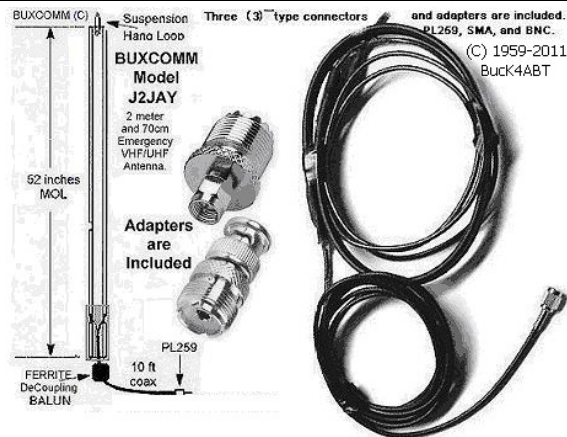

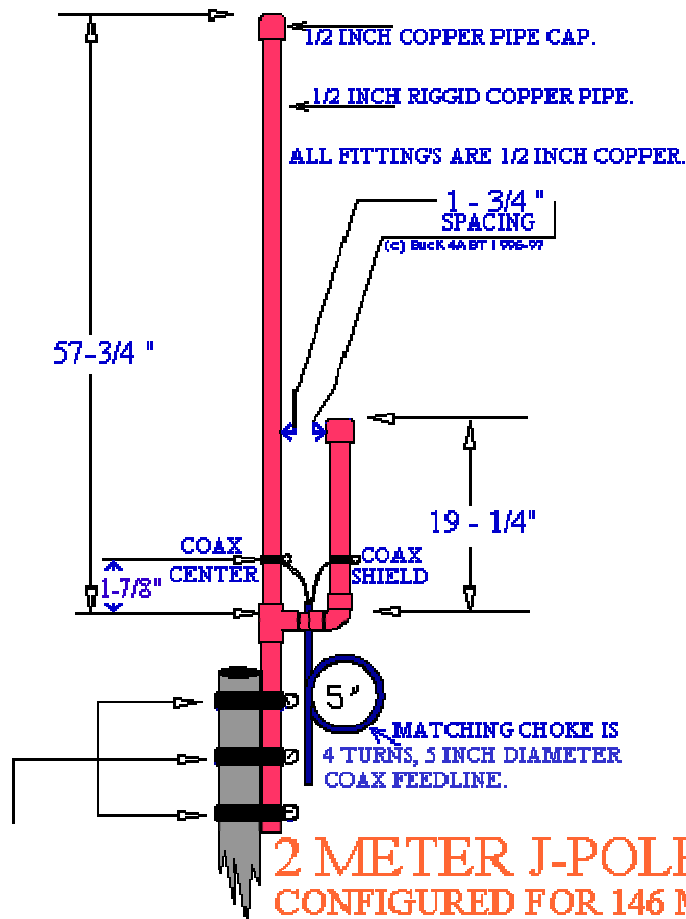

A=Benz-O-Matic propane torch; B=Lead-Free solder; C=Tape measure; D=Tubing cutter; E=Sharpie marking pen; F=Solder Paste; G=1/2 inch copper caps; H=Hardcopy of the above drawing; I=Wet Towel; J=PreCut, ready to assemble parts of the 2 meter J-Pole.

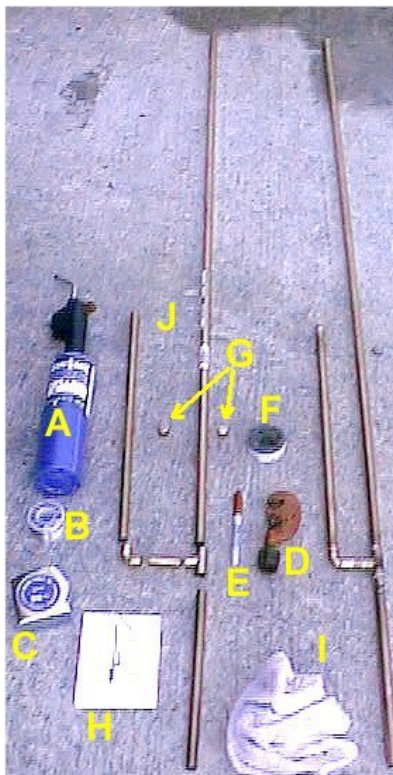

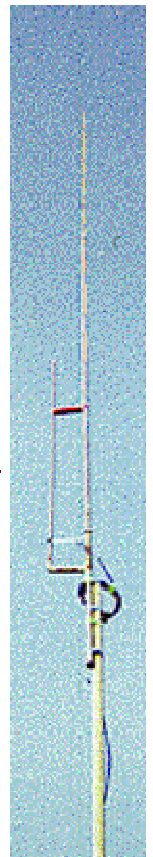
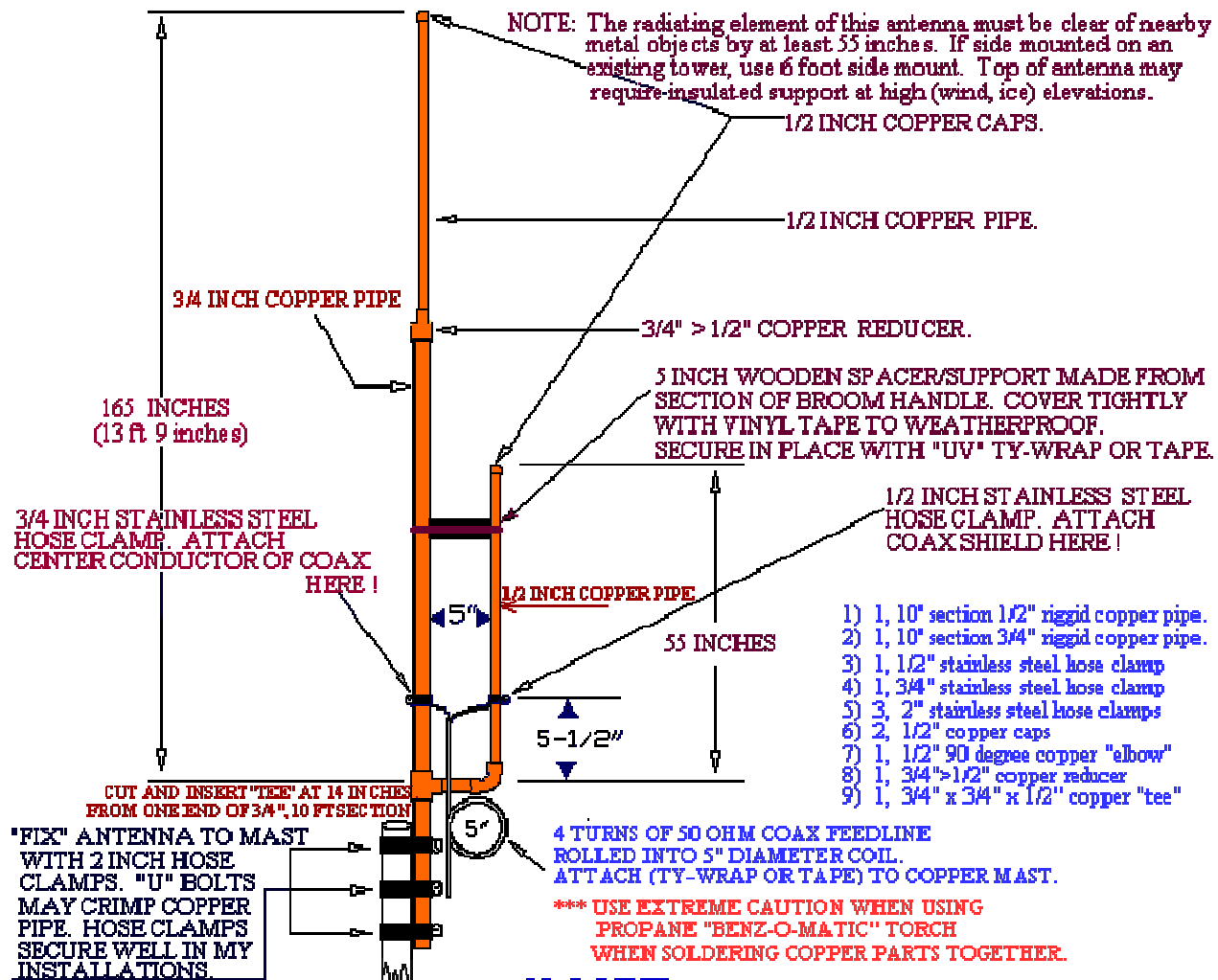

by Buck Rogers **K4ABT**  
**6 METER "J" POLE ANTENNA; DIMENSIONS ARE FOR 51 MHz**

**BUXCOMM J Pole Calculation by BuckK4ABT (C) 1992**

***Center conductor to "Long Element" and Shield to "Short Element."***

One is for 144 to 148 MHz (model JPOL2) and the other is for 430-450 MHz (model JPOL4).  
Both models are shown in the following illustration:



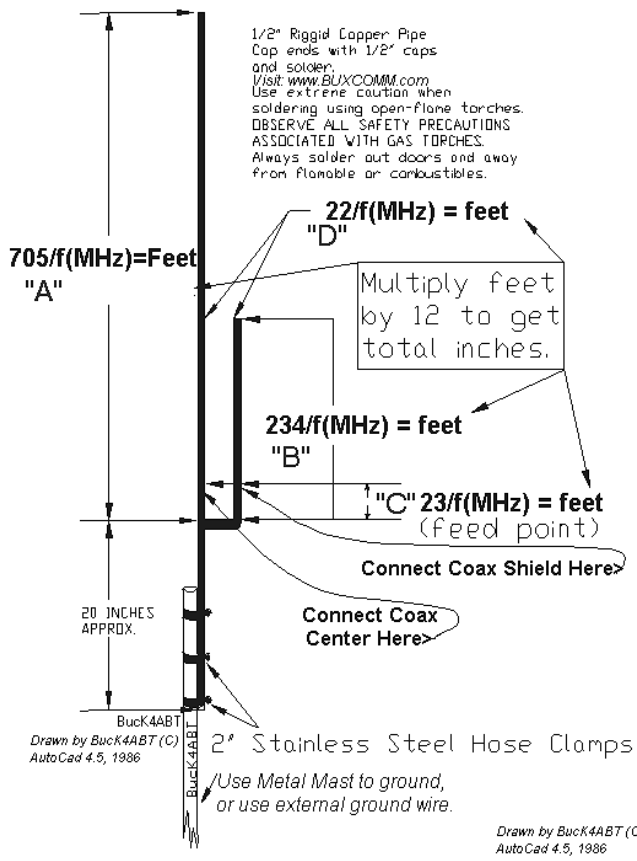

**BUX COMM**  
 Direct Feed  
 J-POLES

For 144-148 mHz  
 Order JPOL2

For 430-450 mHz  
 Order JPOL4

Heavy Duty 5/16"  
 fiber glass polished rod  
 withstands harse  
 weather conditions.  
 More Gain than  
 ground planes.  
 Elements don't corrode  
 or oxidize.

Tower leg or mast.  
 Approximately  
 TEN inches

Can be side mounted on tower leg  
 or on 1-1/4" metal or PVC SKED 40  
 mast. NO radials needed.

SQUARE 1"x1" FiberGlass Rigid Tube  
 U-BOLT fits up to 1-1/2 inch OD mast

18-1/2"

144-148 mHz  
 JPOL2

430-450 mHz  
 JPOL4

57.7"

19.4"

Center to  
 Center

Copper  
 Braid  
 SO239  
 RF INPUT

- \* Very Light Weight
- \* EZ to install
- \* No Radials to increase weight or windload
- \* Makes a great indoor or attic "stealth" antenna.
- \* Easy to mount on apartment guard-rail.
- \* Operate JPOL Mobile
- \* Ideal on VHF-UHF Field-Day

2 meter version: 144 to 150 mHz  
 (model JPOL2)  
 > [CLICK HERE for on-line CATALOG](#)

70cm version: 430-450 mHz  
 (model JPOL4)  
 > [CLICK HERE for on-line CATALOG](#)

The object is to eliminate the need to go through all the calculations on another page of this website.

<p>Great for wireless, radio, satellite and HAM antennas</p> <p><b>Hand Moldable Plastic</b> <b>COAX-SEAL®</b> Seals Connectors from Moisture and Corrosion</p> <p>Effective Moisture-Proofing</p> <ul style="list-style-type: none"> <li>• Provides years of protection</li> <li>• Hand moldable - stays flexible at extreme temperatures</li> <li>• Forms easily to odd shaped connectors</li> <li>• Non-conductive</li> <li>• Non-contaminating</li> </ul>  <p>Fast easy seal for wireless, radio and satellite antennas</p>	<p>For all type of outdoor antenna connections, BALUNS, Coax connectors, coax bulkhead entry panels and more. Use <b>Coax-Seal®</b> to protect any outdoor connection or connector. <b>Coax-Seal</b> is made of a non-conductive, non-contaminating waterproof material that remains flexible at any temperature from -30° to 180°F. Coax connectors that are not waterproof or have exposed solder joints can weaken from oxidation ! Coax-Seal is superior to electrical tape or vinyl sealants for moisture protection. Each box of Coax-Seal contains (60 inches x 1/2 inch) five feet and will protect ten (10) connectors.</p>	<p><a href="#">CAT#, CS104, For all type of outdoor antenna connections, BALUNS, Coax connectors, coax bulkhead entry panels and more.</a></p>
--	--	--

Serving HAM Radio since 1959, On the Web Since 1992

Order Toll Free Monday through Friday, 9 am to 5 pm, 1 800 726 2919 or 1 866 300 1969, Saturday 9 AM to 2 PM Eastern Time

NO MINIMUM ORDERS, Same Day Shipping, except Sunday and Holidays

BUXCOMM Corporation 115 LUENBURG DRIVE EVINGTON, VIRGINIA 24550

BUXCOMM Tech Support is by expert Technicians and Engineers. \*Tech Support; Email; [support@buxcomm.com](mailto:support@buxcomm.com)

Web Page Design and HTML By

G. E. 'Buck' Rogers Sr K4ABT d/b/a BUX CommCo™ © & © and is a trademark of; G.E. "Buck" Rogers Sr., Communications Consultants

All text and graphics on these pages are ©&™ of G. E. Rogers Sr and BUX COMM Corp 1958 - 2011